

版本 REV	工程变更号 ECN No.	变更描述 CHANGED DESCRIPTION	日期 DATE	修改人 MODIFIED BY
A		首次发行(FIRST RELEASE)	2024/1/25	潘奕磊

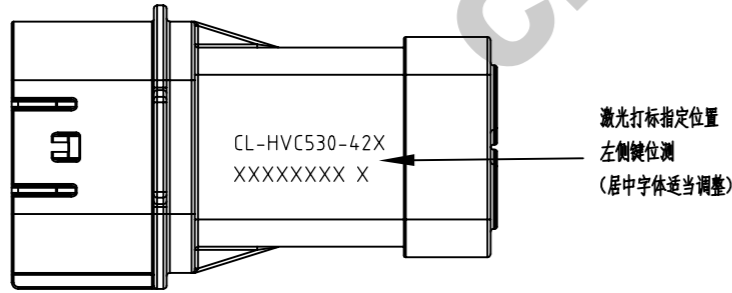

- 技术描述:
1. 插拔寿命: 大于100次;
DURABILITY IS MORE THAN 100 TIMES;
 2. 额定电压: 600V;
RATED VOLTAGE: 600V;
 3. 额定电流: 30A(4平线);
RATED CURRENT: 30A(4mm² CABLE);
 - [C] 4. 绝缘阻抗: 200MΩ;
INSULATION RESISTANCE: 200MΩ;
 - [C] 5. 耐压: 2500V AC/min;
WITHSTANDING VOLTAGE: 2500V AC/min;
 6. 防护等级: IP67, IP6K9K(已插入);
IP2XB(未插入);
IP RATING: IP67, IP6K9K(MATED);
IP2XB(UNMATED);
 7. 工作温度: -40℃至125℃;
OPERATION TEMPERATURE: -40℃至125℃;
 - [C] 8. 阻燃等级: UL94V-0.
FIRE RATING: UL94V-0.
 - [C] 9. 材料符合ROHS和REACH要求
THE MATERIAL MEETS ROHS AND REACH REQUIREMENTS

料号说明(PRODUCT MODEL INSTRUCTION):

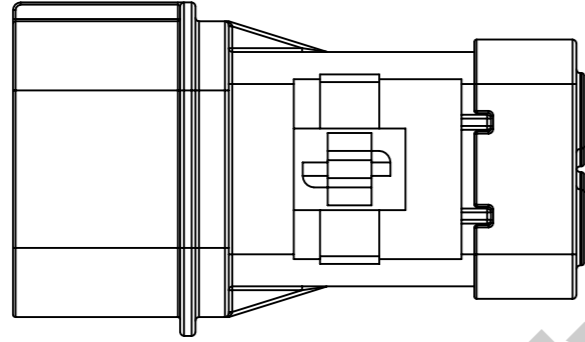
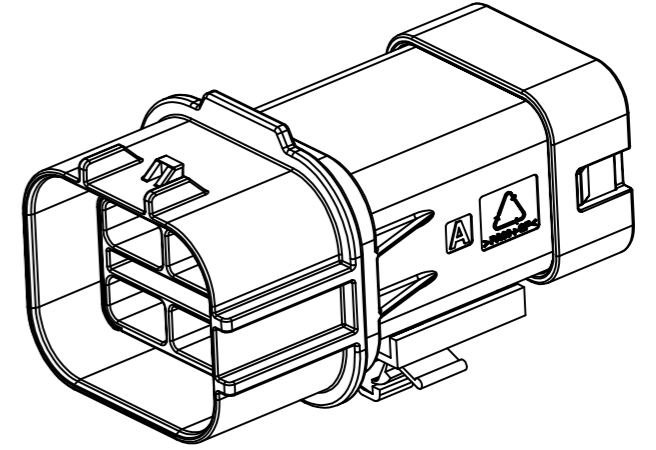
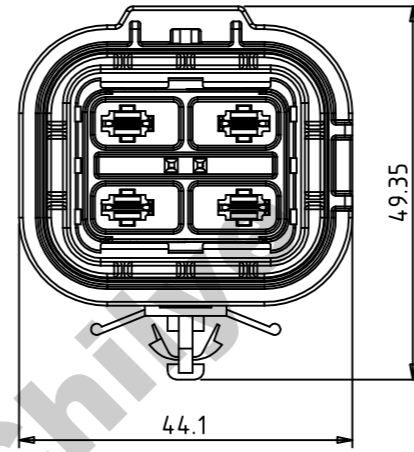
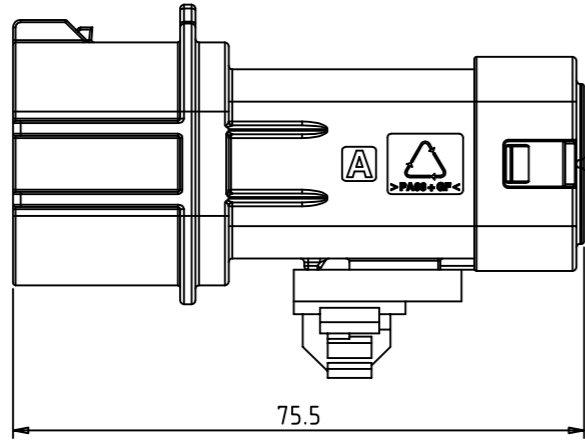
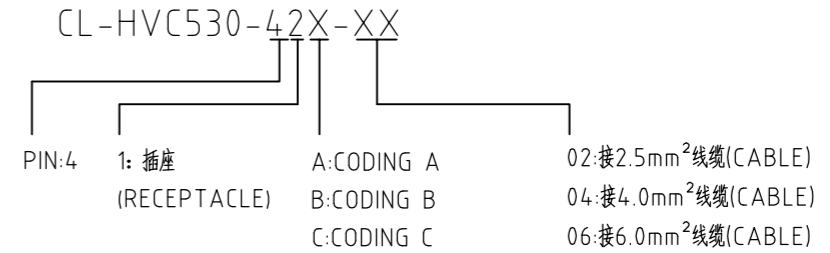

激光打标内容和格式说明:

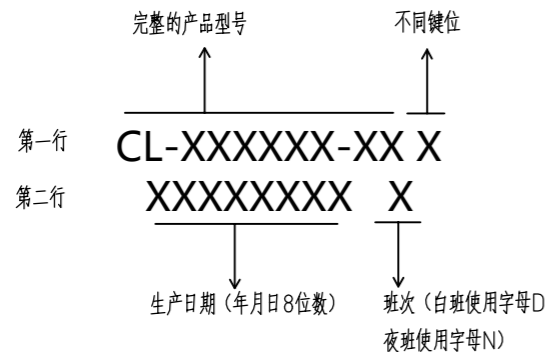

THE DOCUMENT CONTAINS INFORMATION WHICH IS PROPRIETARY TO CHILYE AND SHOULD NOT BE USED WITHOUT WRITTEN PERMISSION		Chilye 智绿		产品名称/PART NAME HVC530 四芯线性插座总成 HVC530 4P RECEPTACLE 180° ASSY	
X.X ±0.3	X° ±1°	第一视角 PROJECTION	设计 DESIGNER	潘奕磊	2024/01/25
X.XX ±0.1	X.X° ±0.5°		标准化 STANDARDIZATION		
重量 WEIGHT			审核 CHECKED		
材料 MATERIAL			核准 APPROVED		
文件类型 DOCUMENT		图纸页数 SHEET		单位 UNIT	图纸 SIZE
CAD		1/2		mm	A3
比例 SCALE		版次 REV			
1:1		A			

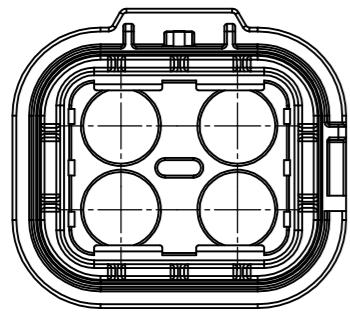

CODING A
CL-HVC530-42A

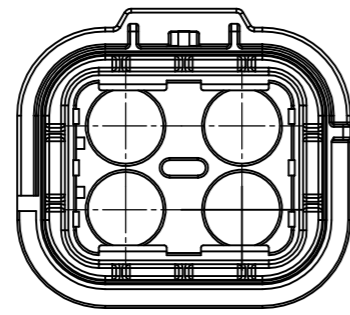

CODING B
CL-HVC530-42A

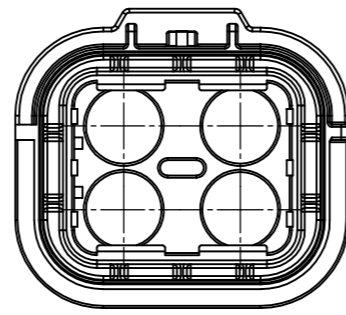

CODING C
CL-HVC530-42A

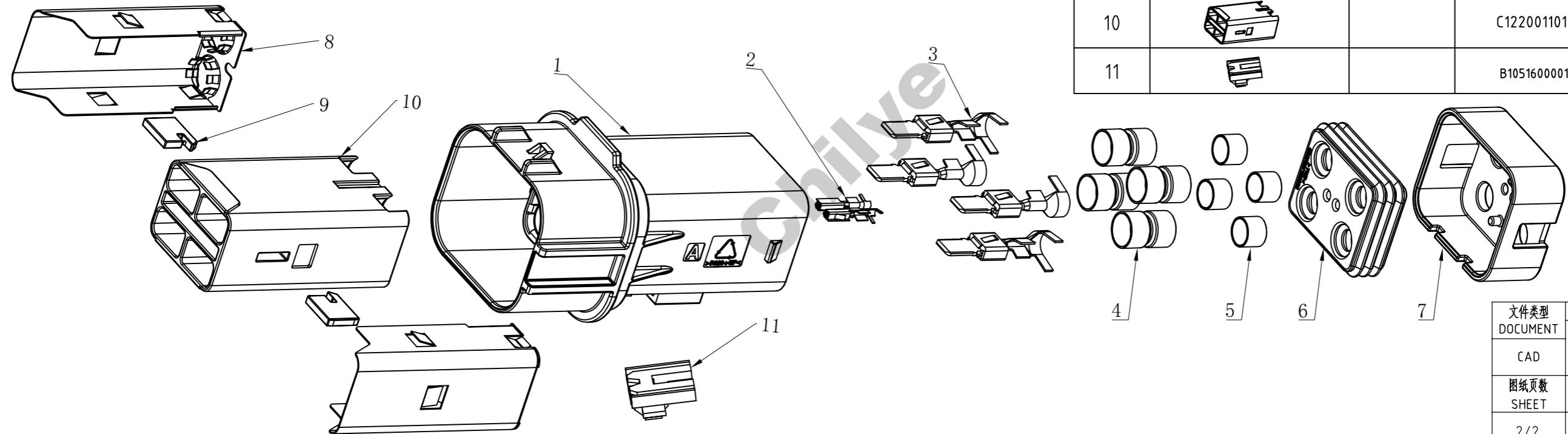

ITEM	PART DWG.	CABLE SIZE (mm ²)	PART NUMBER	D(mm)	QUANTITY
01		—	C1220011011XX	—	1
02		0.5	E1121103044	—	2
03		2.5-4.0	E1121103019	—	4
		4.0-6.0	E1121103034	—	4
04		2.5-4.0	C120001100201	5.85	4
		6.0	C120001100202	6.6	4
05		2.5-4.0	C1200034006	8.0	4
		6.0	C1200011003	8.0	4
06		2.5-6.0	C127001100101	3.4	1
07		2.5-4.0	C1220011013	6.0	1
		6.0	C1220011029	6.7	1
08			C1310011002	—	2
09			C1220011003	—	2
10			C1220011012	—	1
11			B1051600001	—	1

文件类型 DOCUMENT	图纸编号/DRAWING NUMBER			
CAD	C-CL-HVC530-42X			
图纸页数 SHEET	单位 UNIT	图纸 SIZE	比例 SCALE	版次 REV
2/2	mm	A3	1:1	A