

版本 REV	工程变更号 ECN No.	变更描述 CHANGED DESCRIPTION	日期 DATE	修改人 MODIFIED BY
A		首次发行(FIRST RELEASE)	2020/8/22	徐生超

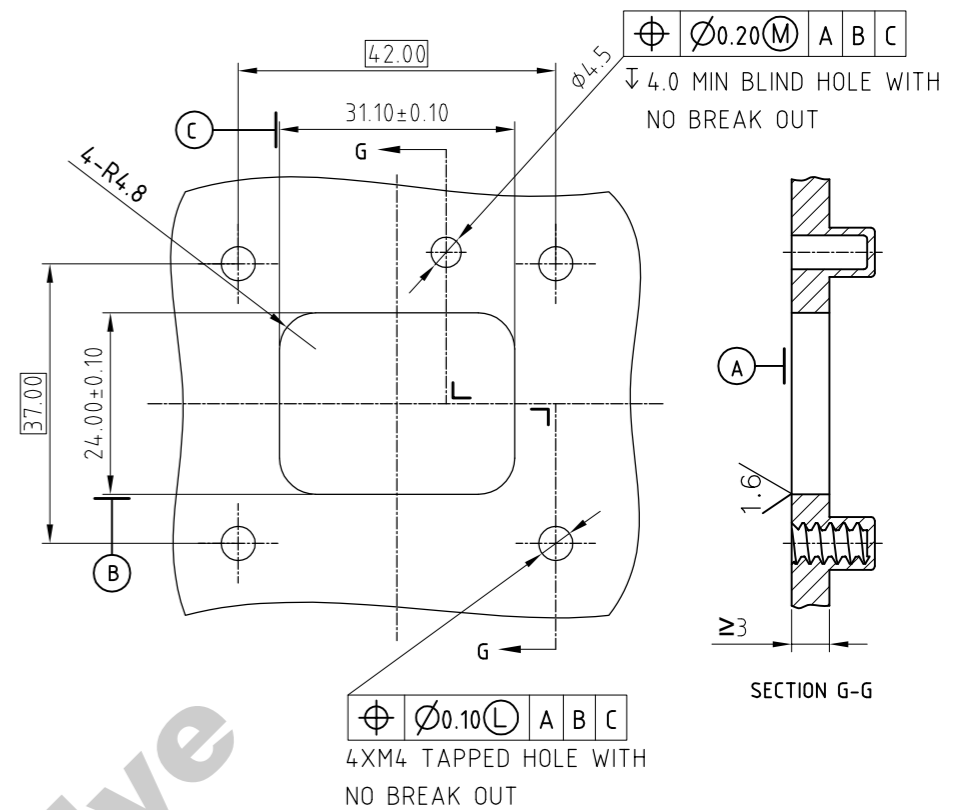

MOUNTING INTERFACE SPECIFICATION  
(CODING A MOUNTING INTERFACE SHOWN)  
REFER TO PAGE 2/2 FOR CODING B~C MOUNTING DIFFERENCES

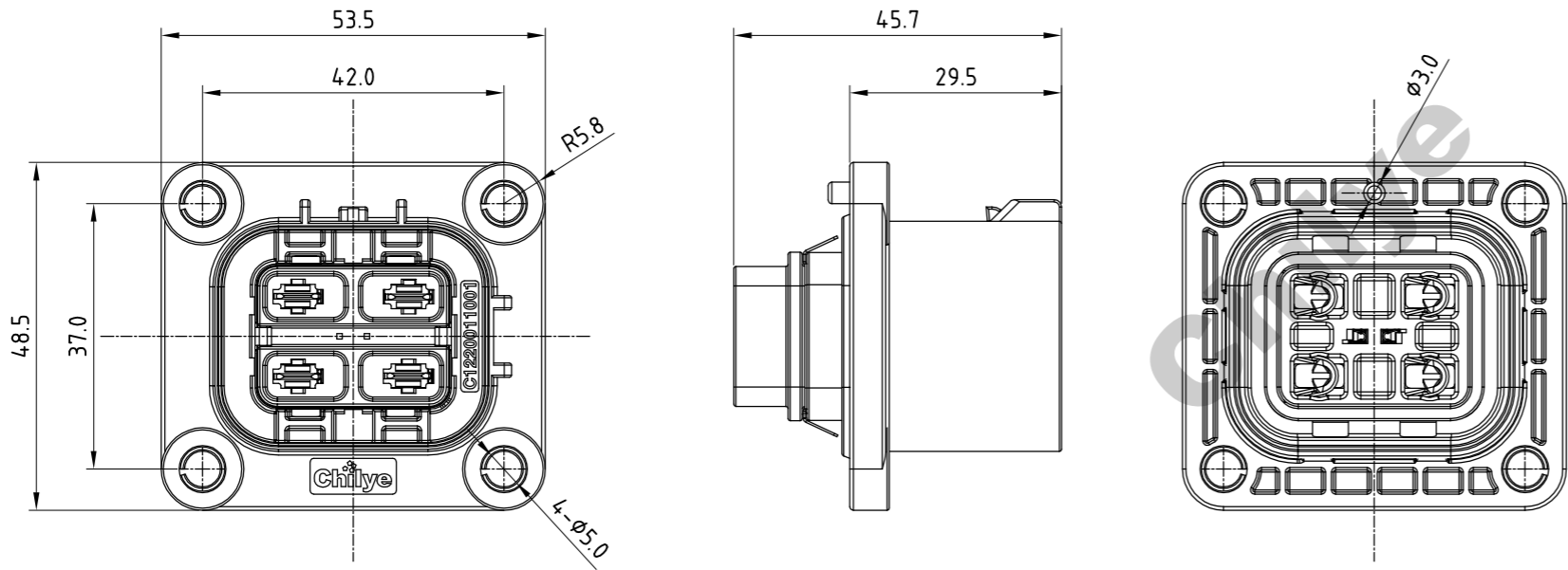
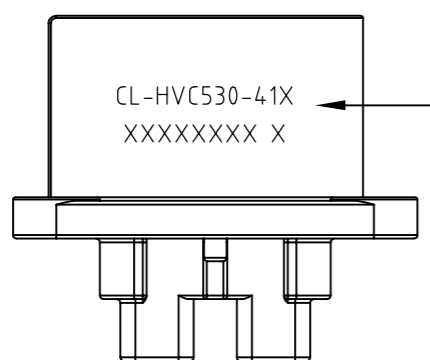

激光打标内容和格式说明:

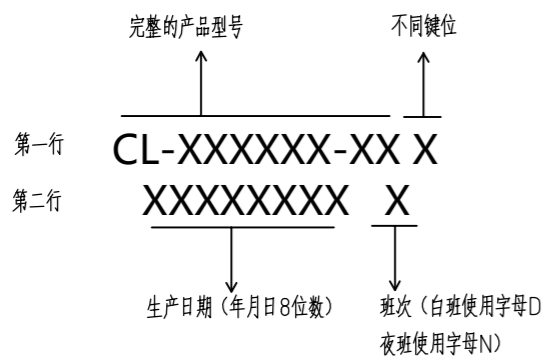

- 技术描述:
1. 插拔寿命: 大于100次;  
DURABILITY IS MORE THAN 100 TIMES;
  2. 额定电压: 600V;  
RATED VOLTAGE: 600V;
  3. 额定电流: 4.0A (6平线);  
RATED CURRENT: 4.0A (6mm<sup>2</sup> CABLE);
  - [C] 4. 绝缘阻抗: 200MΩ;  
INSULATION RESISTANCE: 200MΩ;
  - [C] 5. 耐压: 2500V AC/min;  
WITHSTANDING VOLTAGE: 2500V AC/min;
  6. 防护等级: IP67, IP6K9K (已插合);  
IP2XB (未插合);  
IP RATING: IP67, IP6K9K (MATED);  
IP2XB (UNMATED);
  7. 工作温度: -40℃至125℃;  
OPERATION TEMPERATURE: -40℃ TO 125℃;
  - [C] 8. 阻燃等级: UL94V-0;  
FIRE RATING: UL94V-0;
  9. M4 螺丝扭力: 2.4±0.6N.M;  
M4 SCREW TORQUE: 2.4±0.6N.M;
  10. 螺钉头或垫片外径: ø8~ø12mm.  
SCREW CAP OR GASKET DIAMETER: ø8~ø12mm.
  - [C] 11. 材料符合ROHS和REACH要求  
THE MATERIAL MEETS ROHS AND REACH REQUIREMENTS

料号说明 (PRODUCT MODEL INSTRUCTION):

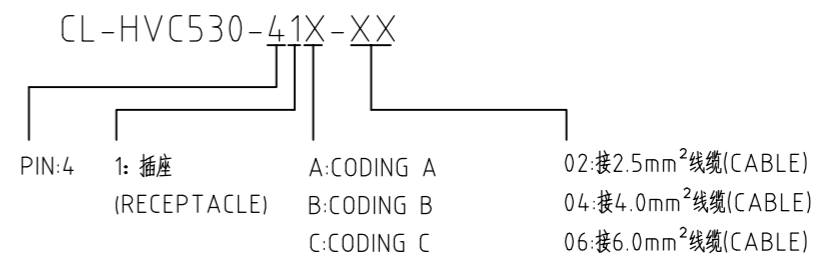

THE DOCUMENT CONTAINS INFORMATION WHICH IS PROPRIETARY TO CHILYE AND SHOULD NOT BE USED WITHOUT WRITTEN PERMISSION				Chilye 智绿			产品名称/PART NAME HVC530 四芯插座总成 HVC530 4P RECEPTACLE ASSY				
X.X ±0.3	X° ±1°	第一视角 PROJECTION	设计 DESIGNER	徐生超	2020/8/22	文件类型 DOCUMENT	图纸编号/DRAWING NUMBER C-CL-HVC530-41X				
X.XX ±0.1	X.X° ±0.5°		标准化 STANDARDIZATION	审核 CHECKED		CAD	图纸页数 SHEET	单位 UNIT	图纸 SIZE	比例 SCALE	版次 REV
重量 WEIGHT			核准 APPROVED			1/2	mm	A3			A

开孔图(MOUNTING INTERFACE)

CODING A  
CL-HVC530-41A

CODING B  
CL-HVC530-41B

CODING C  
CL-HVC530-41C

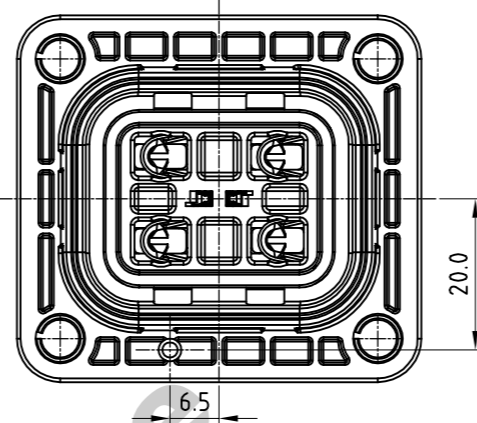
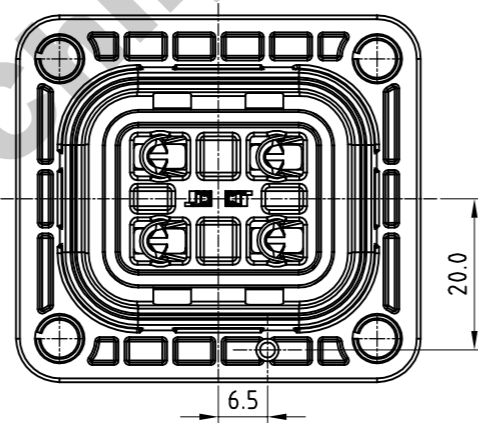
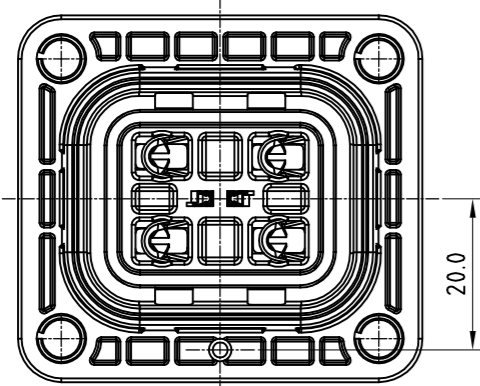
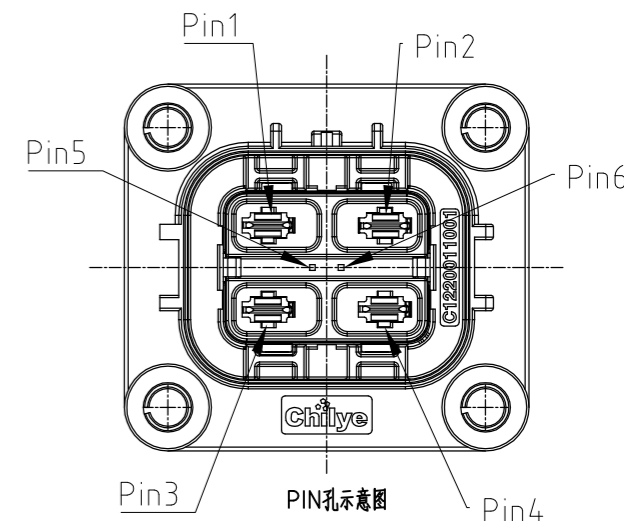
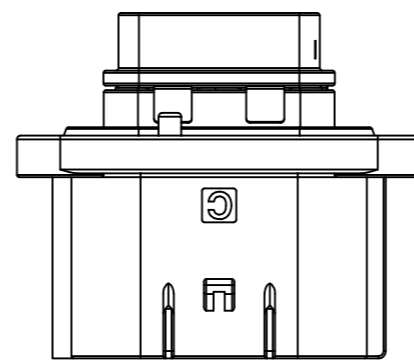
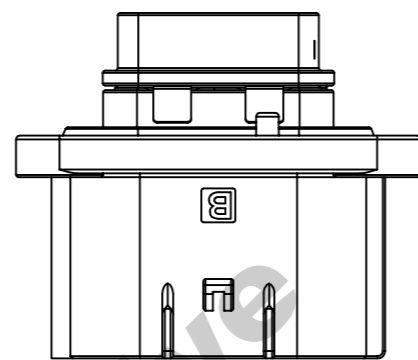
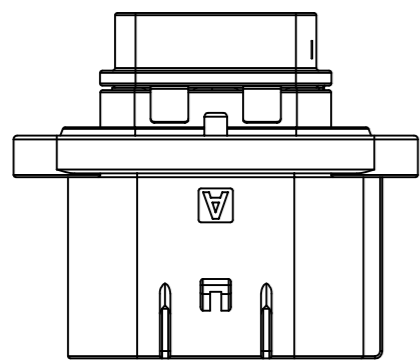
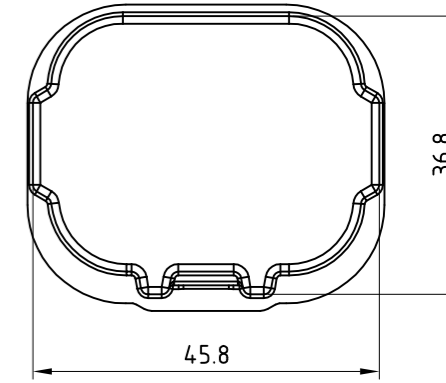
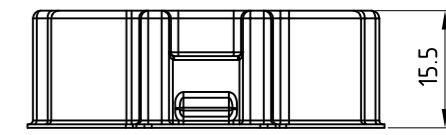
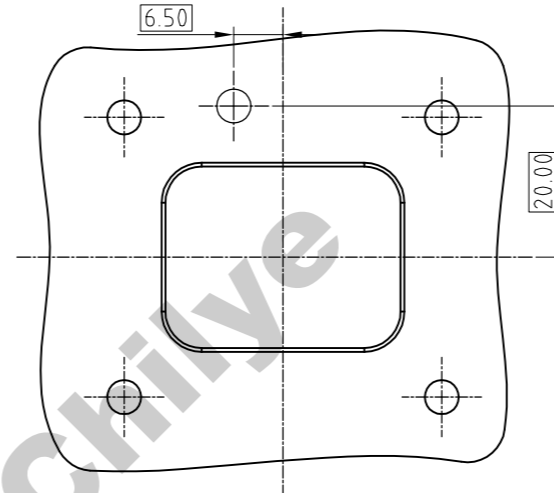
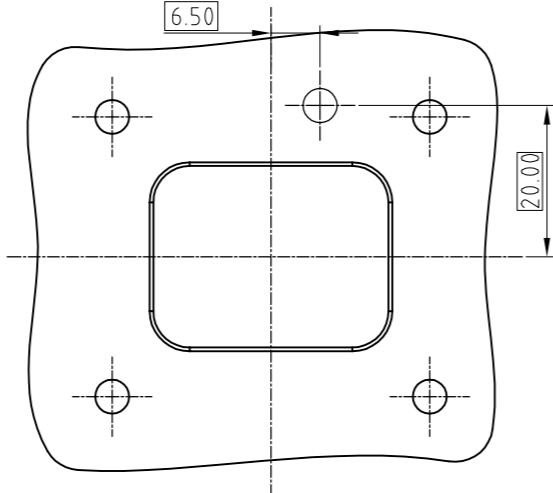
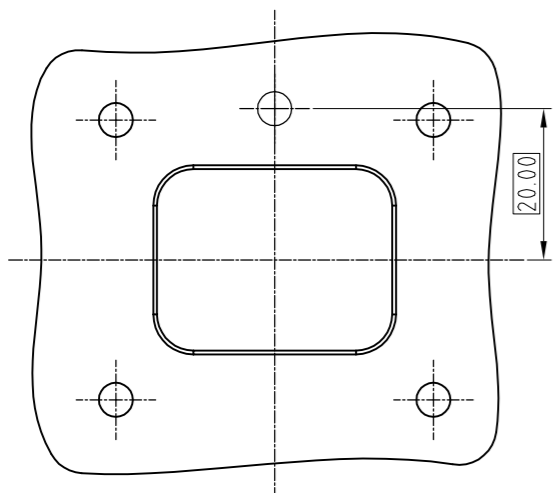

8	C1220011039	4P SOCKET DUST CAP	1	选配
7.3	E1122003006	TAB5.8X0.8 FOR 6.0mm <sup>2</sup> WIRE	4	
7.2	E1122003007	TAB5.8X0.8 FOR 4.0mm <sup>2</sup> WIRE	4	
7.1	E1122003007	TAB5.8X0.8 FOR 2.5mm <sup>2</sup> WIRE	4	
6	E1122003001	MQS RECEPTACLE FOR 0.5~0.75mm <sup>2</sup> WIRE	2	
5	C1270011005	SEAL	1	
4	C1220011003	CLIP	2	
3	C1220011002	INNER HOUSING HVC530 4P	1	
2	C1310011001	SHIELD	1	
1.3	C122001100103	HVC530 4P RECEPTACLE C ASSY	1	
1.2	C122001100102	HVC530 4P RECEPTACLE B ASSY	1	
1.1	C122001100101	HVC530 4P RECEPTACLE A ASSY	1	
ITEM	PART NO	DESCRIPTION	QTY	REMARK

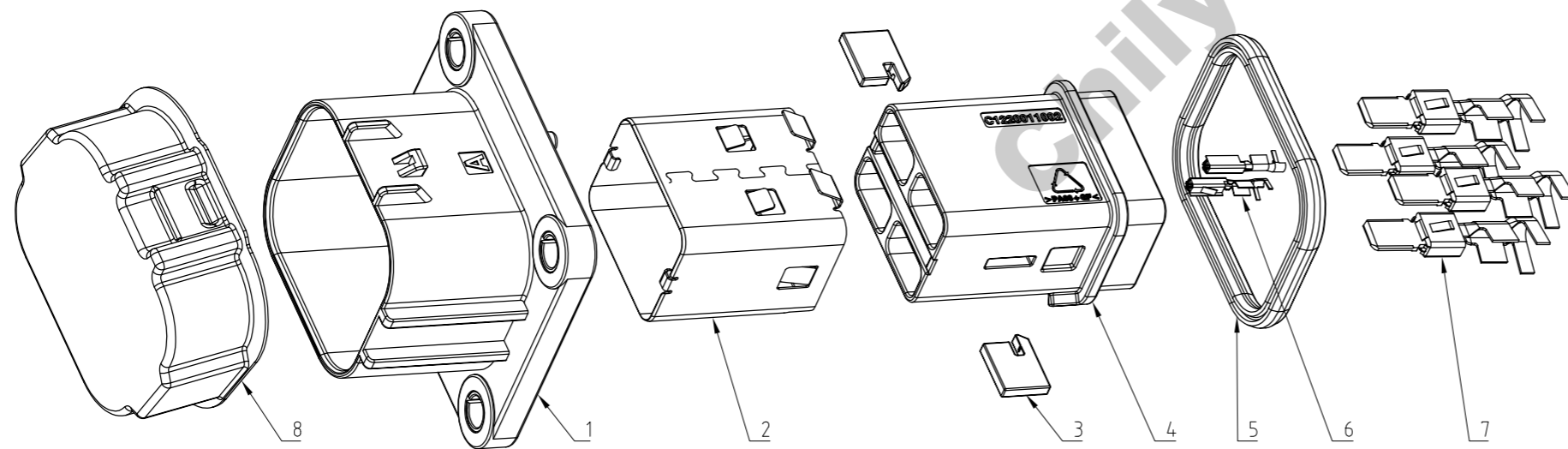

6.0mm <sup>2</sup>	4.9~5.3 mm	文件类型 DOCUMENT	图纸编号/DRAWING NUMBER			
4.0mm <sup>2</sup>	3.3~4.6 mm	CAD	C-CL-HVC530-41X			
2.5mm <sup>2</sup>	2.5~3.8 mm	图纸页数 SHEET	单位 UNIT	图幅 SIZE	比例 SCALE	版次 REV
SIZE	OUTSIDE DIAMETER	2/2	mm	A3	×	A
SCOPE OF CABLE OUTSIDE DIAMETER						